



# Original User Manual Up-right Vacuum Cleaner GTR1500-EU



220-240 V~; 50 / 60 Hz; 850 W; Class I; IP20

english	User Manual.....	1-9
deutsch	Betriebsanleitung.....	xxx
français	Notice d'utilisation .....	xxx
nederlands	Gebbruiksaanwijzing.....	xxx
italiano	Istruzioni sull'uso.....	xxx
español	Instrucciones de manejo.....	xxx
portugues	Instruções de operação.....	xxx

**VIPER CLEANING EQUIPMENT CO., LTD.**  
Liang Bian village, Liao Bu town, Dong Guan city, Guang Dong Province, China

Company information:

[WWW.vipercleaning.eu](http://WWW.vipercleaning.eu)

[info-eu@vipercleaning.com](mailto:info-eu@vipercleaning.com)



**TABLE OF CONTENTS**

**INTRODUCTION..... 2**

    MANUAL PURPOSE AND CONTENTS ..... 2

    TARGET..... 2

    HOW TO KEEP THIS MANUAL..... 2

    DECLARATION OF CONFORMITY ..... 2

    OTHER REFERENCE MANUALS..... 2

    SPARE PARTS AND MAINTENANCE..... 2

    CHANGES AND IMPROVEMENTS ..... 3

    OPERATION CAPABILITIES ..... 3

    CONVENTIONS ..... 3

**UNPACKING/DELIVERY ..... 3**

**SAFETY ..... 3**

    SYMBOLS ..... 3

    GENERAL INSTRUCTIONS..... 4

**MACHINE DESCRIPTION ..... 6**

    MACHINE STRUCTURE .....6

    TECHNICAL DATA.....7

    WIRING DIAGRAM..... 8

**OPERATION OF UP-RIGHT VACUUM..... 9**

    BASIC OPERATION..... 9-10

    MAINTENANCE..... 10-11

    STOREAGE.....11

## INTENDED USE OF THE APPLIANCE

This dust vacuum cleaner is a cleaning appliance for commercial use, for example in hotels, schools, hospitals, factories, shops, offices, and rental businesses.  
The appliance is intended for sucking dry, non-flammable dusts of textile floorings and wall coverings.

## INTRODUCTION (CAUTION: Read the instruction manual before using the appliance)



### NOTE

*The numbers in brackets refer to the components shown in Machine Description chapter.*

## MANUAL PURPOSE AND CONTENTS

The purpose of this Manual is to provide the operator with all necessary information to use the machine properly, in a safe and autonomous way. It contains information about technical data, safety, operation, storage, maintenance, spare parts and disposal. Before performing any procedure on the machine, the operators and qualified technicians must read this Manual carefully. Contact VIPER in case of doubts concerning the interpretation of the instructions and for any further information.

## TARGET

This Manual is intended for operators and technicians qualified to perform the machine maintenance.  
The operators must not perform procedures reserved for qualified technicians. VIPER will not be answerable for damages coming from the non-observance of this prohibition.

## HOW TO KEEP THIS MANUAL

The User Manual must be kept near the machine, inside an adequate case, away from liquids and other substances that can cause damage to it.

## DECLARATION OF CONFORMITY

The declaration of conformity, supplied with the machine, certifies the machine conformity with the law in force.



### NOTE

*Two copies of the original declaration of conformity are provided together with the machine documentation.  
CE-declaration is print in Quick Start Guide*

## IDENTIFICATION DATA

The machine model and serial number are marked on the plate .

The machine model year is written in the declaration of conformity and it is also indicated by the first two figures of the machine serial number.

This information is useful when requiring machine spare parts. Use the following table to write down the machine identification data.

MACHINE model .....
MACHINE serial number .....

## OTHER REFERENCE MANUALS

- Service Manual (that can be consulted at VIPER Service Centers)
- Spare Parts List (see [www.vipercleaning.eu](http://www.vipercleaning.eu))

## SPARE PARTS AND MAINTENANCE

All necessary operating, maintenance and repair procedures must be performed out by qualified personnel or by VIPER Service Centers. Only original spare parts and accessories must be used.  
Contact VIPER for service or to order spare parts and accessories, specifying the machine model and serial number.

## CHANGES AND IMPROVEMENTS

VIPER constantly improves its products and reserves the right to make changes and improvements at its discretion without being obliged to apply such benefits to the machines that were previously sold.

Any change and/or addition of accessories must be approved and performed by VIPER.

## CONVENTIONS

Forward, backward, front, rear, left or right and up are intended with reference to the operator's position, that is to say in working position with the handle.

## UNPACKING/DELIVERY

To unpack the machine, carefully follow the instructions on the packing.

When the machine is delivered, check that the packing and the machine were not damaged during transportation. In case of visible damages, keep the packing and have it checked by the carrier that delivered it. Call the carrier immediately to fill in a damage claim. Check that the machine is equipped with the following features:

1. Technical documents:
  - UP-RIGHT VACUUM CLEANER Quick Start Guide

## SAFETY

The following symbols indicate potentially dangerous situations. Always read this information carefully and take all necessary precautions to safeguard people and property.

The operator's cooperation is essential in order to prevent injury. No accident prevention program is effective without the total cooperation of the person responsible for the machine operation. Most of the accidents that may occur in a factory, while working or moving around, are caused by failure to comply with the simplest rules for exercising prudence. A careful and prudent operator is the best guarantee against accidents and is essential for successful completion of any prevention program.

## SYMBOLS



### DANGER!

*It indicates a dangerous situation with risk of death for the operator.*



### WARNING!

*It indicates a potential risk of injury for people or damage to objects.*



### CAUTION!

*It indicates a caution related to important or useful functions.  
Pay careful attention to the paragraphs marked by this symbol.*



### NOTE

*It indicates the necessity to refer to the User Manual before performing any procedure.*

## GENERAL INSTRUCTIONS

Specific warnings and cautions to inform about potential damages to people and machine are shown below.



### DANGER!



- *Always disconnect the power supply cable when the machine is not in use, before performing maintenance procedures and before replacing parts or converting the appliance to another.*
- *This machine must be used by properly trained and authorised personnel only. Children or disabled people cannot use this machine.*
- *Do not wear jewels when working near electrical components.*
- *Do not work under the lifted machine without supporting it with safety stands.*
- *Do not operate the machine near toxic, dangerous, flammable and/or explosive powders, liquids or vapours.*



### WARNING!



- *The machine power supply cable is grounded and the relevant plug is grounded too. In case of machine malfunction or breakdown, grounding connection reduces the risk of electric shock.*
- *The power supply cable plug must be connected to an appropriate outlet, which is grounded according to law in force.*
- *This appliance is not intended for use by persons (including children) with reduced physical, sensory or mental capabilities, or lack of experience and knowledge, unless they have been given supervision or instruction concerning use of the appliance by a person responsible for their safety.*
- *Children should be supervised to ensure that they do not play with the appliance.*
- *If the supply cord is damaged, it must be replaced by the manufacturer, its service agent or similarly qualified persons in order to avoid a hazard.*
- *Improper connection can cause electric shock. Consult a qualified technician to make sure that the outlet is properly grounded.*
- *Do not tamper with the power supply cable plug. If the power supply cable plug cannot be connected to the outlet, have new grounded outlet installed by a qualified technician, according to the law in force.*
- *Before connecting the power supply cable to the electrical mains, check that frequency and voltage, shown on the machine serial number plate, match the electrical mains voltage.*
- *Regularly examine the supply cable for damage, such as cracking or ageing, cuts, etc. If the damaged is found, replace the cord before further use.*
- *To avoid any risk, if the power supply cable is damaged, contact VIPER Service Center or a qualified technician.*
- *Do not pull or carry the machine by the power supply cable and never use the power supply cable as a handle. Do not close a door on the power supply cable, or pull the power supply cable around sharp edges or corners. Do not run the machine on the power supply cable.*
- *Keep the power supply cable away from heated surfaces.*
- *To reduce the risk of fire, electric shock, or injury, do not leave the machine unattended when it is plugged in. Disconnect the machine from the electrical mains when not in use and before performing maintenance procedures.*
- *To avoid electric shock, do not expose the machine to rain or other bad weather conditions. Store the machine indoors, in a dry place.*
- *Do not allow to be used as a toy. Close attention is necessary when used near children.*
- *Use only as shown in this Manual. Use only VIPER's recommended accessories.*
- *Take all necessary precautions to prevent hair, jewels and loose clothes from being caught by the machine moving parts.*
- *Do not leave the machine unattended without being sure that it cannot move independently.*
- *While using this machine, take care not to cause damage to people or objects.*
- *Do not bump into shelves or scaffoldings, especially where there is a risk of falling objects.*
- *Do not put any can containing fluids on the machine.*
- *This appliance is not suitable for picking up hazardous dust.*
- *This appliance is for dry use only and is not be used or stored outdoors in wet conditions.*
- *Use extra care when cleaning on stairs.*
- *This appliance is suitable for commercial use, for example in hotels, schools, hospitals, shops, offices, and rental businesses.*
- *The following materials should not be sucked into the vacuum cleaner:*
  - *hot materials (burning cigarettes, hot ashes, etc.)*
  - *liquids*
  - *flammable, explosive dusts(e.g. magnesium or aluminium dust, etc.)*
- *The machine storage temperature must be between 0°C and +40°C.*
- *If used on plush carpet or carpet with thick padding, do not leave machine in one place with machine turned on. When using accessory tools, keep floor brush off carpet by keeping handle in locked position and lowering handle with one hand to raise brush off floor. Operate accessories with other hand.*

- *The humidity must be between 30% and 95%.*
- *Do not use the machine as a means of transport.*
- *Do not use the machine on slopes with a gradient exceeding the specifications.*
- *In case of fire, use a powder fire extinguisher, not a water one.*
- *Do not tamper with the machine safety guards and follow the ordinary maintenance instructions scrupulously.*
- *Do not allow any object to enter into the openings. Do not use the machine if the openings are clogged. Always keep the openings free from dust, hairs and any other foreign material which could reduce the air flow.*
- *Do not remove or modify the plates affixed to the machine.*
- *If the machine is used according to the instructions, the vibrations are not dangerous. The machine vibration level is less than 2.5 m/s<sup>2</sup> (98/37/EEC-EN 1033/1995).*
- *This machine cannot be used on roads or public streets.*
- *In case of machine malfunctions, ensure that these are not due to lack of maintenance. If necessary, request assistance from the authorised personnel or from an authorised Service Center.*
- *If the machine*
  - *does not work properly*
  - *is damaged*
  - *has water or foam leaks*
  - *has been left outdoors exposed to bad weather conditions*
  - *is wet or has been dropped into water**turn it off immediately and contact VIPER Service Center or a qualified technician.*
- *If parts must be replaced, require ORIGINAL spare parts from an Authorised Dealer or Retailer.*
- *To ensure machine proper and safe operation, the scheduled maintenance shown in the relevant chapter of this Manual, must be performed by the authorised personnel or by an authorised Service Center.*
- *Carefully read all the instructions before performing any maintenance/repair procedure.*
- *Do not wash the machine with direct or pressurized water jets, or with corrosive substances.*
- **WARNING** *only use the accessory provide with the appliance, The use of other non original accessory may impair safety.*
- *The machine must be disposed of properly, because of the presence of toxic-harmful materials (electrical components, etc.), which are subject to standards that require disposal in special centres (see Scraping chapter).*
- *For indoor use only.*
- **WARNING** *do not allow the supply cord to come into contact with the rotating brushes*

## MACHINE DESCRIPTION

### MACHINE STRUCTURE

1. On/off switch
2. Hose
3. Handle assembly
4. Telescopic handle grip
5. Cover release
6. Dust bag housing
7. Cover
8. Foot pedal
9. Brush/suction head
10. Brush roller release
11. Handle grip
12. Cable
13. Hose hook
14. Retaining ring
15. Carrying handle
16. Cable hook
17. Dusting tool
18. Crevice tool
19. Upholstery tool



GTR1500-EU

**TECHNICAL DATA**

<b>Model</b>	<b>GTR1500-EU</b>
Voltage	220 V-240 V
Power	850 W
Current	4 A
Frequency	50/60 Hz
Dust bag capacitor	6L
Vacuum	1957 mm H <sub>2</sub> O
Flow rate	1900 L/Min
Working width	381 MM
Brush speed	3000 rpm
Sound pressure level at workstation	75 dB(A)
Weight	9,7 Kg
Length of Power cord	12 M



WIRING DIAGRAM FOR GTR1500-EU

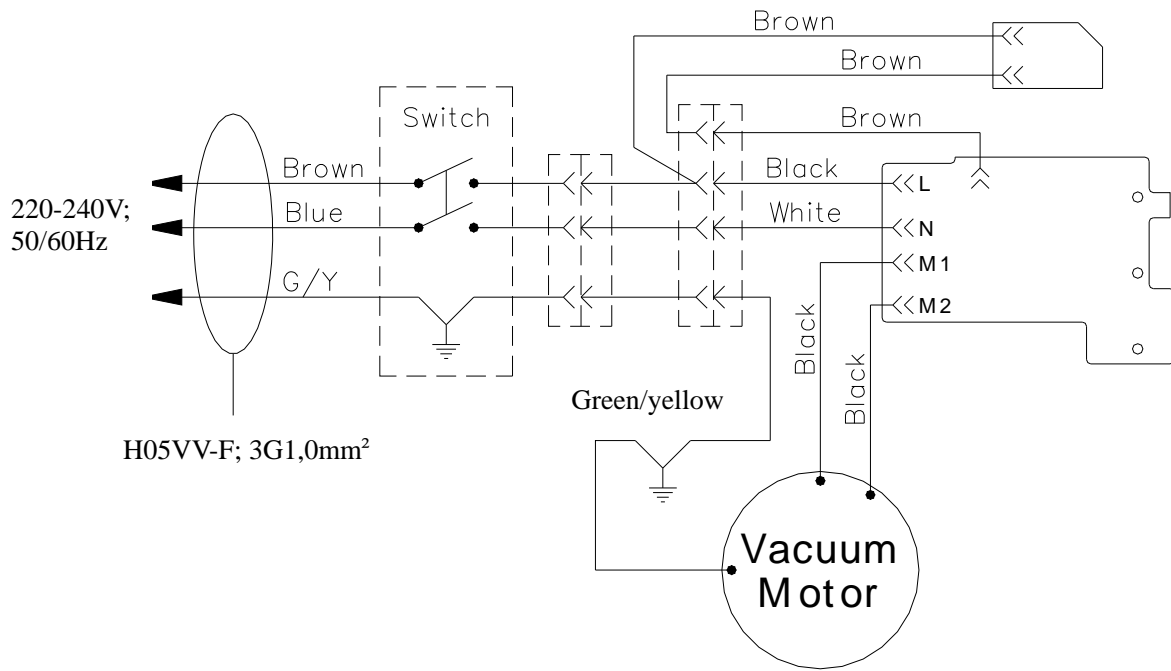

## SETUP OF UPRIGHT VACUUM

!!! Read operators manual thoroughly prior to operating or servicing this machine.

Carefully check the shipping carton for signs of damage. Report any carton damage to carrier immediately.

Check carton contents to ensure carton is complete. Contact your Viper distributor if anything is missing.

Contents:

- Upright Vacuum assembly
- Paper filter bag (inside tank)
- Exhaust filter (installed inside tank)
- Handle tube with power cord
- Flexible suction hose
- Extendable wand
- Dusting brush (installed on back of machine)
- Crevice tool (installed on back of machine)
- Upholstery tool (installed on back of machine)

## ASSEMBLY OF HANDLE & POWER CORD

- 1) Raise handle latch and place handle assembly into top of bag housing as shown in photo below.
- 2) Lower handle latch to lock handle assembly in place.



## ADDITIONAL MACHINE SETUP

- 1) Ensure the paper filter bag and exhaust filter cartridge are in the bag housing of the machine, and positioned in their proper places.
- 2) Securely replace bag housing cover prior to operating machine.



- 3) Place the crevice tool, dusting brush and upholstery tool into their holding spots on the rear of the bag housing.

## MACHINE OPERATION

!!! Read operators manual thoroughly prior to operating or servicing this machine.

!!! Do not operate machine without filter bag or filter cartridge properly installed.

### STANDARD UPRIGHT MODE

- 1) Plug power cord into a grounded outlet.

!!! Do not use an extension cord in conjunction with the standard power cord.

- 2) Step on red head release lever to lower the head to operating position.
- 3) Turn power switch to “on” position.
- 4) While operating machine, periodically check the lights located on the head of the machine.
  - a. Green Light = Machine is functioning properly
  - b. Yellow Light = Bag is full (machine will automatically shut down after :35 seconds once bag is full)
  - c. Red Light = Check brush assembly
- 5) If the Yellow Light is illuminated, it is time to replace the filter bag with a new one, or the pickup hose has an obstruction.
- 6) If the Red Light is illuminated, UNPLUG THE MACHINE and check the brush for obstructions.

#### VACUUMING WITH ACCESSORY TOOLS AND WAND

**!!! While using the wand and accessories, the brush inside the head assembly is spinning.**

**!!! Though the brush is spinning, it is elevated off the floor, so it will not damage the carpet.**

- 1) Plug power cord into a grounded outlet.

**!!! Do not use an extension cord in conjunction with the standard power cord.**

- 2) While keeping the machine in storage position, remove the wand from its storage position in the back of the housing.
- 3) Attach the desired attachment to the end of the wand.
- 4) Turn power switch to “on” position.
- 5) While operating machine, periodically check the lights

located on the head of the machine.

- a. Green Light = Machine is functioning properly
  - b. Yellow Light = Bag is full (machine will automatically shut down after :35 seconds once bag is full)
  - c. Red Light = Check brush assembly
- 6) If the Yellow Light is illuminated, it is time to replace the filter bag with a new one, or the pickup hose has an obstruction.
  - 7) If the Red Light is illuminated, UNPLUG THE MACHINE and check the brush for obstructions.

#### MAINTENANCE

To keep the machine performing well for many years, please follow the following maintenance procedures.

**!!! Always confirm that the machine is unplugged prior to performing any maintenance or repairs.**

- 1) Check filter bag prior to use to confirm that it is not full or damaged. For optimal performance, the bag should be replaced when  $\frac{3}{4}$  full, or if the bag is damaged.
- 2) Check exhaust filter to ensure it is clean and properly installed.
- 3) Check brush assembly to ensure that the brush bristles are not worn out, or clogged with debris.
- 4) Clean outside of machine with a mild cleaner and cloth.
- 5) If the supply cord is damaged, it must be replaced by the manufacturer, its service agent or similarly qualified persons in order to avoid a hazard.

- 6) Check vacuum hose for holes and clogs. If either is found, replace hose immediately.
- 7) Lubricate wheels with a water resistant lubricant on a monthly basis.
- 8) Check machine for loose or missing nuts, screw and bolts and replace as necessary.

### **MACHINE STORAGE**

- 1) Unplug machine from power source
- 2) Store machine in upright position in a dry area

### **TROUBLESHOOTING**

#### **MACHINE DOES NOT OPERATE**

- Bad power cord
  - May need to be replaced
- Bad on/off switch
  - May need to be replaced
- Poor wiring
  - Contact Service Center
- Defective vacuum motor
  - Contact service center
- Work carbon brushes in vacuum motor
  - Contact service center

#### **POOR VACUUM PERFORMANCE**

- Filter bag is full
  - Replace filter bag
- Clogged hose
  - Remove obstruction
- Clogged extension wand
  - Remove obstruction
- Defective vacuum hose
  - Replace hose
- Loose vacuum hose connections
  - Check and tighten all hose connections
- Front cover loose
  - Check and secure front bag cover housing

#### **POOR BRUSH PICKUP**

- Worn brush assembly
  - Replace brush assembly
- Debris caught in brush
  - Remove clogged debris



Do not dispose of electrical appliances as unsorted municipal waste, use separate collection facilities.